



Hydraulic Double Acting Block Cylinder

Model BM

Model BN

Rod Side Mounting

Index

Model No. Selection _____	43
Technical Data _____	44
Specifications _____	44
Hydraulic Circuit Diagram _____	44
Without Guide Flange Option _____	45
External Dimensions for Mounting _____	46
Mounting Details _____	47
With Guide Flange Option _____	49
External Dimensions for Mounting _____	50
Mounting Details _____	51
Instructions _____	53
Hydraulic Connection _____	53
Cautions _____	54

Model No. Selection

B **M** - **G** **P** **040** **M**

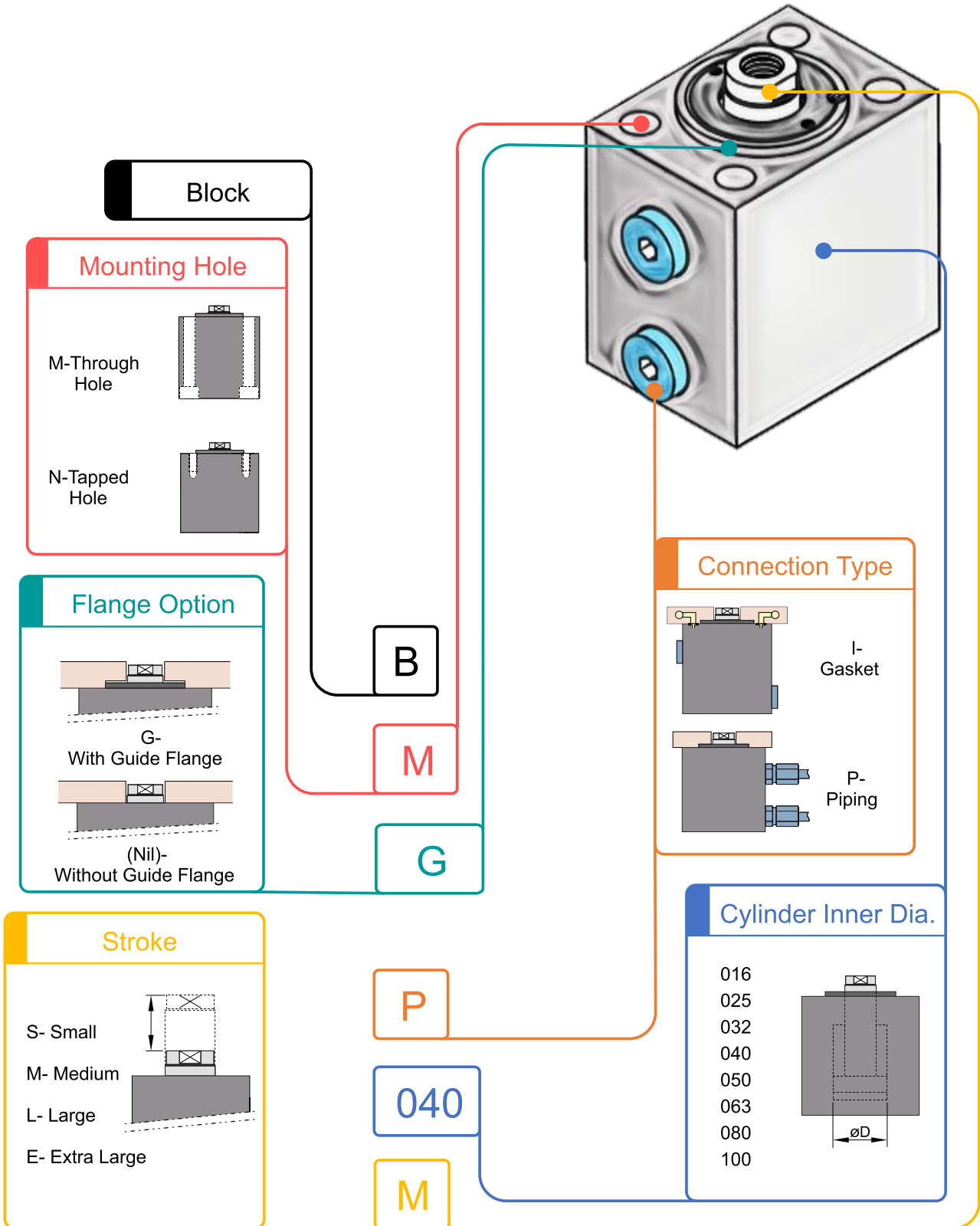

Technical Data

Specifications

Model No.		B□-□□016□	B□-□□025□	B□-□□032□	B□-□□040□	B□-□□050□	B□-□□063□	B□-□□080□	B□-□□100□
Cylinder Inner Diameter	mm	16	25	32	40	50	63	80	100
Rod Diameter	mm	10	16	20	25	32	40	50	63
Cylinder Force	Push	kN	1.38	3.37	5.52	8.62	13.47	21.4	34.50
	Pull	kN	0.84	1.99	3.36	5.25	7.95	12.77	21.02
Effective area	Push	cm ²	2.01	4.9	8.04	12.56	19.63	31.17	50.26
	Pull	cm ²	1.22	2.89	4.9	7.65	11.59	18.6	30.63
Small Stroke (Code-S)		B□-□□016S	B□-□□025S	B□-□□032S	B□-□□040S	B□-□□050S	B□-□□063S	B□-□□080S	B□-□□100S
Full Stroke	mm	16	16	16	25	25	25	50	50
Cylinder Capacity	Push	cm ³	3.21	7.85	12.86	31.41	49.08	77.93	251.32
	Pull	cm ³	1.96	4.63	7.84	19.14	28.98	46.51	153.15
Mass	Kg	0.9	1.2	1.9	2.8	4.5	7.5	16.7	26.8
Medium Stroke (Code-M)		B□-□□016M	B□-□□025M	B□-□□032M	B□-□□040M	B□-□□050M	B□-□□063M	B□-□□080M	B□-□□100M
Full Stroke	mm	25	25	25	50	50	50	75	75
Cylinder Capacity	Push	cm ³	5.02	12.27	20.1	62.83	98.17	155.86	376.99
	Pull	cm ³	3.06	7.24	12.25	38.28	57.96	93.03	229.72
Mass	Kg	1	1.4	2.1	3.7	5.6	9.3	19.6	31.4
Large Stroke (Code-L)		B□-□□016L	B□-□□025L	B□-□□032L	B□-□□040L	B□-□□050L	B□-□□063L	B□-□□080L	B□-□□100L
Full Stroke	mm	32	32	32	75	75	75	100	100
Cylinder Capacity	Push	cm ³	6.43	15.7	25.73	94.24	147.26	233.79	502.65
	Pull	cm ³	3.92	9.27	15.68	57.43	86.94	139.54	306.3
Mass	Kg	1.1	1.5	2.3	4.5	6.8	11	22.5	36
Extra Large Stroke (Code-E)		B□-□□016E	B□-□□025E	B□-□□032E	B□-□□040E	B□-□□050E	B□-□□063E	B□-□□080E	B□-□□100E
Full Stroke	mm	50	50	50	100	100	100	125	125
Cylinder Capacity	Push	cm ³	10.05	24.54	40.21	125.66	196.34	311.72	628.31
	Pull	cm ³	6.12	14.49	24.5	76.57	115.92	186.06	382.88
Mass	Kg	1.4	1.9	2.7	5.3	8	12.8	25.4	40.6

- Pressure Range: - 10-70 Bar
- Operating Temperature: - 0-70 °C
- Fluid Used: - General Mineral Based Hydraulic Oil (ISO – VG32 Equivalent)
- Given Value of Cylinder Forces Are at 70 Bar Pressure.

Hydraulic Circuit Diagram

For flow control valve, we recommend the meter-in control. If meter-out control is used due to area difference it will cause back pressure and become high pressure. This can lead to malfunction of the system.

- Please be aware when designing the circuit.

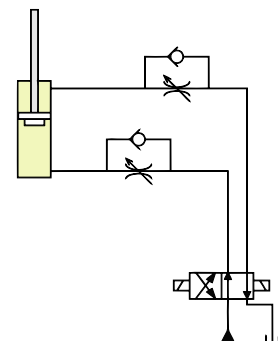

Without Guide Flange Option

BM-□□□: Through hole Option

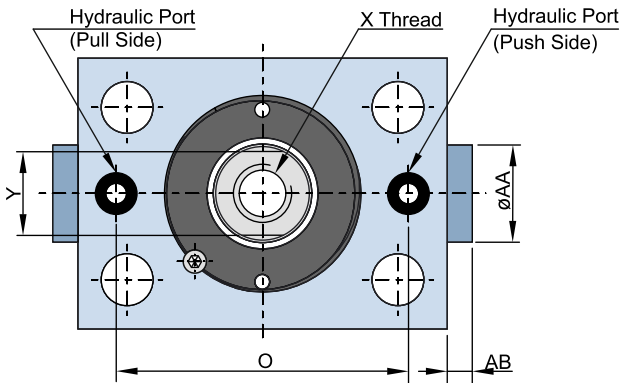

BN-□□□: Tapped hole Option

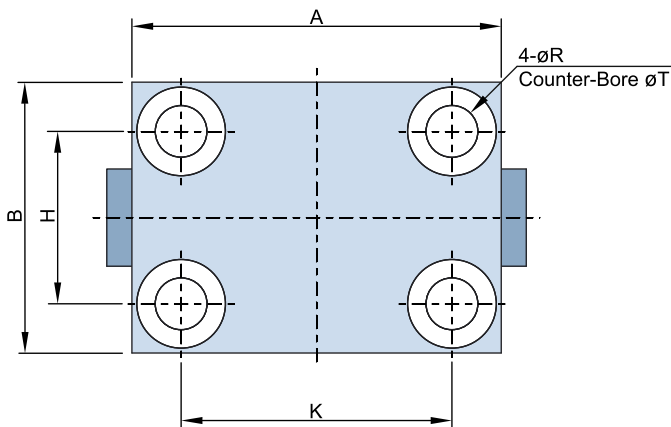
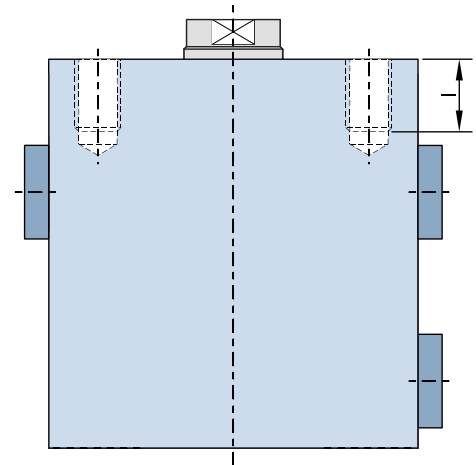
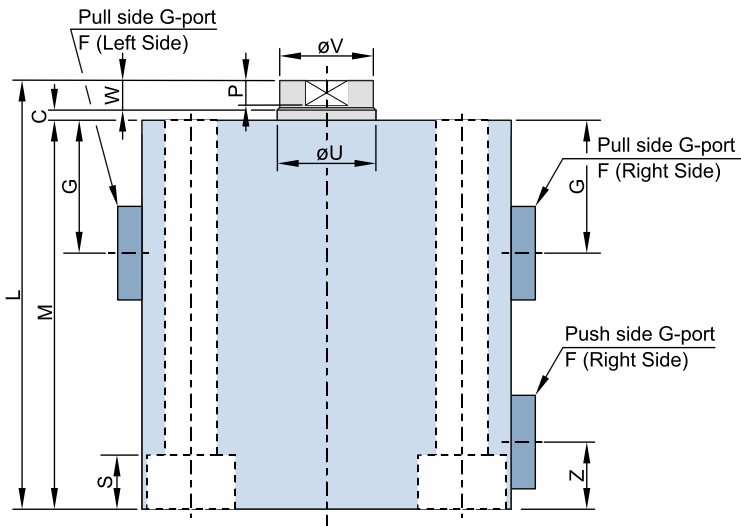
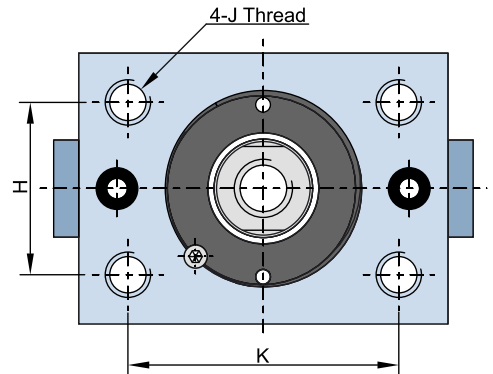

- Both figure shows the retracted position of cylinder.
- For gasket option (B□-I□□), gasket holes will be provided. Pull side G-port is on left side of cylinder and push side G-port is on right side of the cylinder. (Pull side G-port of right side will not be provided.) For more details, please refer page no.-53
- In a piping option (B□-P□□), gasket holes will not be provided. Pull side G-port and push side G-port, both are on right side of the cylinder. (Pull side G-port of left side will not be provided.) For more details, please refer page no.-53

External Dimensions for Mounting

Model No.	B□-□016□	B□-□025□	B□-□032□	B□-□040□	B□-□050□	B□-□063□	B□-□080□	B□-□100□
A	60	65	75	85	100	125	160	200
B	35	45	55	63	75	95	120	150
C	2	2	4	4	4	5	4	3
F	G1/4	G1/4	G1/4	G1/4	G1/4	G3/8	G3/8	G3/8
G	22	22.5	27	29	35	35	43	44
I	9	12	15	15	18	24	30	36
J (Nominal X Pitch)	M6X1	M8X1.25	M10X1.5	M10X1.5	M12X1.75	M16X2	M20X2.5	M24X3
H	22	30	35	40	45	65	80	108
K	40	50	55	63	76	95	120	158
O	44	52	59	69	80	99	135	174
P	3	4	5	5	5	8	9	10
ØR	6.8	9	11	11	14	17.5	22	26
S	4	9	11	11	13	17	21	25
ØT	11	14	18	18	19	25	33	40
ØU	10	16	20	25	32	40	50	63
ØV	9.2	15	19	24	30.5	38.7	48	61
W	4	5	6	6	6	9	10	12
X (Nominal X Pitch X Depth)	M6X1X10	M10X1.5X15	M12X1.75X15	M16X2X25	M20X2.5X30	M27X2.5X40	M30X3X40	M42X4X60
Y	8	13	17	22	27	36	44	56
Z	13	14	14	14	15	19	19	22
ØAA	19	19	19	19	19	22	22	22
AB	5	5	5	5	5	5	5	5
Stroke Code-S (Small)								
Stroke	16	16	16	25	25	25	50	50
L	68	70.5	80	91	101	111	148	153
M	62	63.5	70	81	91	97	134	138
Stroke Code-M (Medium)								
Stroke	25	25	25	50	50	50	75	75
L	77	79.5	89	116	126	136	173	178
M	71	72.5	79	106	116	122	159	163
Stroke Code-L (Large)								
Stroke	32	32	32	75	75	75	100	100
L	84	86.5	96	141	151	161	198	203
M	78	79.5	86	131	141	147	184	188
Stroke Code-E (Extra Large)								
Stroke	50	50	50	100	100	100	125	125
L	102	104.5	114	166	176	186	223	228
M	96	97.5	104	156	166	172	209	213

Mounting Details

BM-□□□: Through hole Option

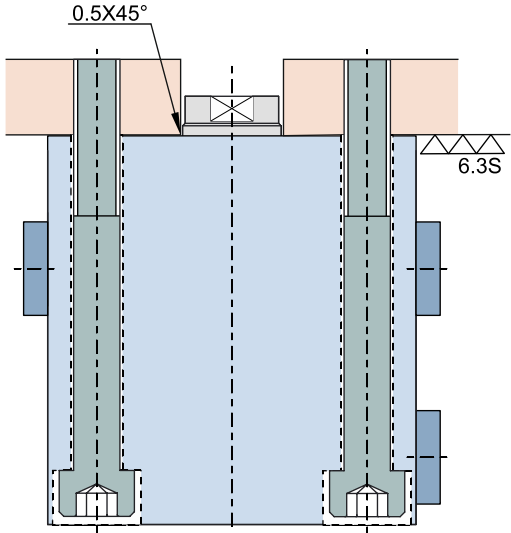

BN-□□□: Tapped hole Option

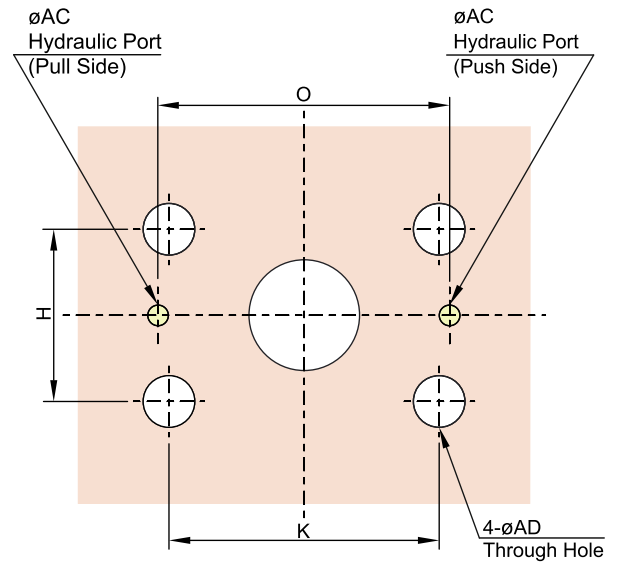
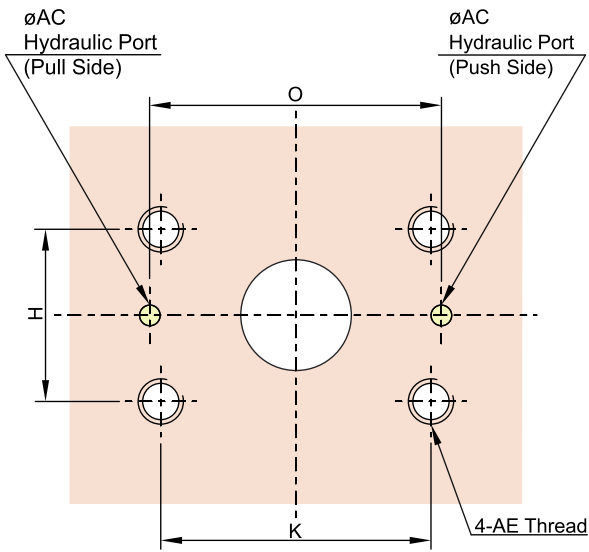
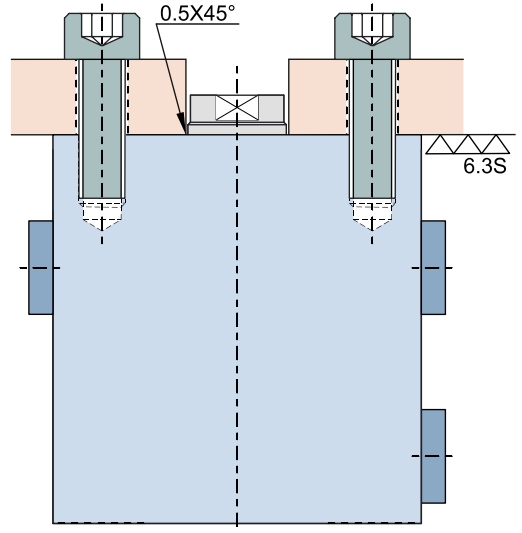

Model No.	B□-□016□	B□-□025□	B□-□032□	B□-□040□	B□-□050□	B□-□063□	B□-□080□	B□-□100□
H	22	30	35	40	45	65	80	108
K	40	50	55	63	76	95	120	158
O	44	52	59	69	80	99	135	174
ØAC	3	4	4	4	5	5	5	6
ØAD	6.8	9	11	11	14	17.5	22	26
AE (Nominal X Pitch)	M6X1	M8X1.25	M10X1.5	M10X1.5	M12X1.75	M16X2	M20X2.5	M24X3

- Mounting bolts are not provided. Please prepare them according to the mounting height referring to mounting dimensions.
- Flow control valve is sold separately. Select the right model of flow control valve according to the size of the cylinder. See page - 139.
- The piston rod has female thread. No contact bolt is included. Prepare them according to the dimensions and application.
- G-thread plug is included and O-ring is provided at gasket option holes.
- For piping option, gasket holes will not be provided.
- When choosing gasket option, piping option holes will be provided for flow control valve. A flow control valve is mountable on G-ports of the cylinder.
- Remove plugs when choosing piping in gasket option (O-ring must be used in gasket option holes.).
- For gasket option (B□-I□□), gasket holes will be provided. Pull side G-port is on left side of cylinder and push side G-port is on right side of the cylinder. (Pull side G-port of right side will not be provided.) For more details, please refer page no.-53
- In a piping option (B□-P□□), gasket holes will not be provided. Pull side G-port and push side G-port, both are on right side of the cylinder. (Pull side G-port of left side will not be provided.) For more details, please refer page no.-53

With Guide Flange Option

BM-G□□□: Through hole Option

BN-G□□□: Tapped hole Option

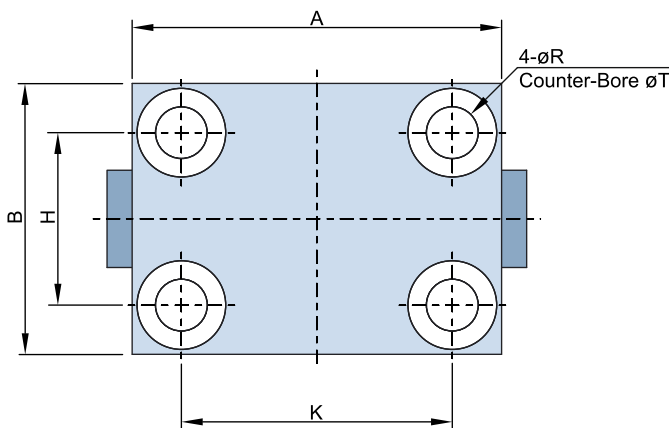
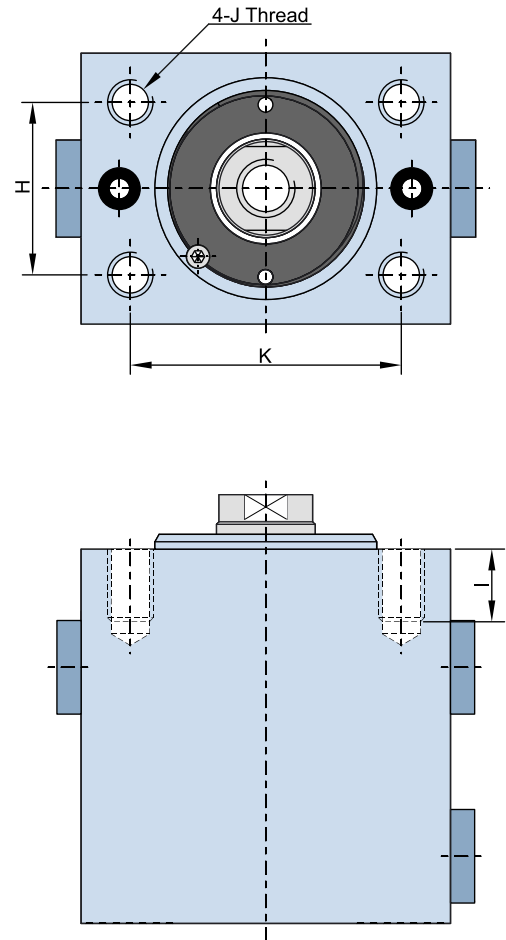
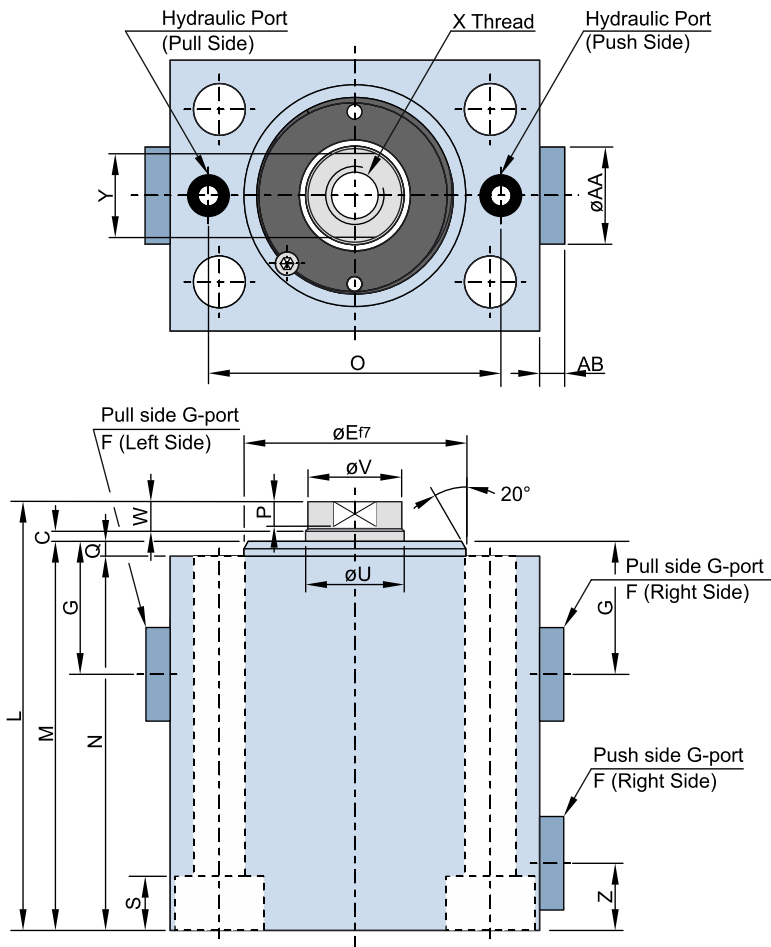

- Both figure shows the retracted positon of cylinder.
- In a gasket option (B□-G□□), gasket holes will be provided. Pull side G-port is on left side of cylinder and push side G-port is on right side of the cylinder. (Pull side G-port of right side will not be provided.) For more details, please refer page no.-53
- For piping option (B□-GP□□), gasket holes will not be provided. Pull side G-port and push side G-port, both are on right side of the cylinder. (Pull side G-port of left side will not be provided.) For more details, please refer page no.-53

External Dimensions for Mounting

Model No.	B□-G□016□	B□-G□025□	B□-G□032□	B□-G□040□	B□-G□050□	B□-G□063□	B□-G□080□	B□-G□100□
A	60	65	75	85	100	125	160	200
B	35	45	55	63	75	95	120	150
C	2	2	4	4	4	5	4	3
F	G1/4	G1/4	G1/4	G1/4	G1/4	G3/8	G3/8	G3/8
G	22	22.5	27	29	35	35	43	44
I	9	12	15	15	18	24	30	36
J (Nominal X Pitch)	M6X1	M8X1.25	M10X1.5	M10X1.5	M12X1.75	M16X2	M20X2.5	M24X3
H	22	30	35	40	45	65	80	108
K	40	50	55	63	76	95	120	158
O	44	52	59	69	80	99	135	174
P	3	4	5	5	5	8	9	10
E	30	40	45	56	65	80	105	125
Q	3	3	3	3	3	3	3	3
ØR	6.8	9	11	11	14	17.5	22	26
S	4	9	11	11	13	17	21	25
ØT	11	14	18	18	19	25	33	40
ØU	10	16	20	25	32	40	50	63
ØV	9.2	15	19	24	30.5	38.7	48	61
W	4	5	6	6	6	9	10	12
X (Nominal X Pitch X Depth)	M6X1X10	M10X1.5X15	M12X1.75X15	M16X2X25	M20X2.5X30	M27X2.5X40	M30X3X40	M42X4X60
Y	8	13	17	22	27	36	44	56
Z	13	14	14	14	15	19	19	22
ØAA	19	19	19	19	19	22	22	22
AB	5	5	5	5	5	5	5	5
Stroke Code-S (Small)								
Stroke	16	16	16	25	25	25	50	50
L	68	70.5	80	91	101	111	148	153
M	62	63.5	70	81	91	97	134	138
N	59	60.5	67	78	88	94	131	135
Stroke Code-M (Medium)								
Stroke	25	25	25	50	50	50	75	75
L	77	79.5	89	116	126	136	173	178
M	71	72.5	79	106	116	122	159	163
N	68	69.5	76	103	113	119	156	160
Stroke Code-L (Large)								
Stroke	32	32	32	75	75	75	100	100
L	84	86.5	96	141	151	161	198	203
M	78	79.5	86	131	141	147	184	188
N	75	76.5	83	128	138	144	181	185
Stroke Code-E (Extra Large)								
Stroke	50	50	50	100	100	100	125	125
L	102	104.5	114	166	176	186	223	228
M	96	97.5	104	156	166	172	209	213
N	93	94.5	101	153	163	169	206	210

Mounting Details

BM-G□□□: Through hole Option

BN-G□□□: Tapped hole Option

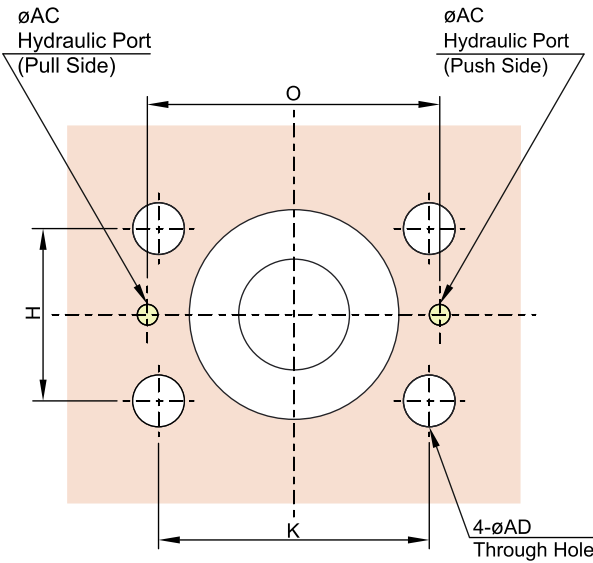
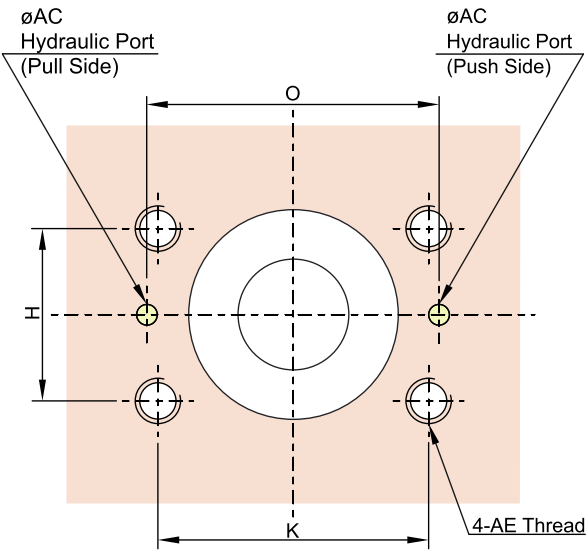
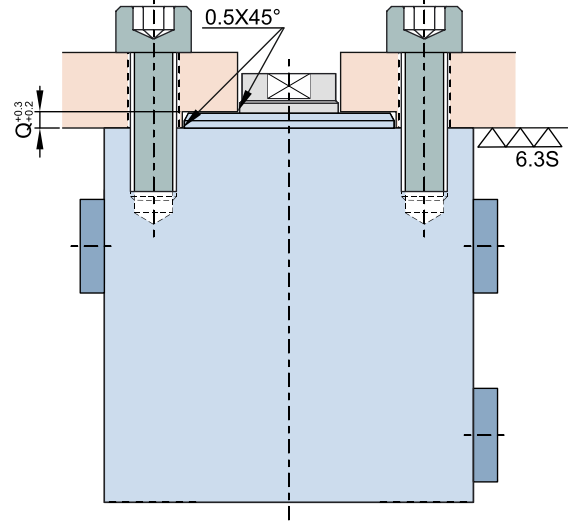
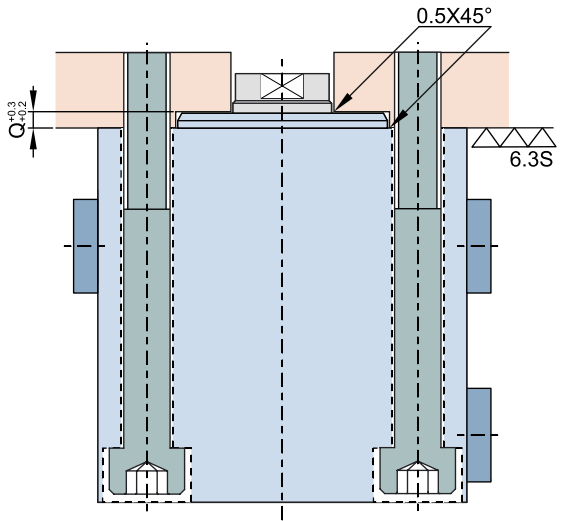

Model No.	B□-G□016□	B□-G□025□	B□-G□032□	B□-G□040□	B□-G□050□	B□-G□063□	B□-G□080□	B□-G□100□
H	22	30	35	40	45	65	80	108
K	40	50	55	63	76	95	120	158
O	44	52	59	69	80	99	135	174
Q	3	3	3	3	3	3	3	3
øAC	3	4	4	4	5	5	5	6
øAD	6.8	9	11	11	14	17.5	22	26
AE (Nominal X Pitch)	M6X1	M8X1.25	M10X1.5	M10X1.5	M12X1.75	M16X2	M20X2.5	M24X3

- Mounting bolts are not provided. Please prepare them according to the mounting height referring to mounting dimensions.
- Flow control valve is sold separately. Select the right model of flow control valve according to the size of the cylinder. See page - 139.
- The piston rod has female thread. No contact bolt is included. Prepare them according to the dimensions and application.
- G-thread plug is included and O-ring is provided at gasket option holes.
- For piping option, gasket holes will not be provided.
- When choosing gasket option, piping option holes will be provided for flow control valve. A flow control valve is mountable on G-ports of the cylinder.
- Remove plugs when choosing piping in gasket option (O-ring must be used in gasket option holes.).
- For gasket option (B□-GI□□), gasket holes will be provided. Pull side G-port is on left side of cylinder and push side G-port is on right side of the cylinder. (Pull side G-port of right side will not be provided.) For more details, please refer page no.-53
- In a piping option (B□-GP□□), gasket holes will not be provided. Pull side G-port and push side G-port, both are on right side of the cylinder. (Pull side G-port of left side will not be provided.) For more details, please refer page no.-53

Instructions

Hydraulic Connection

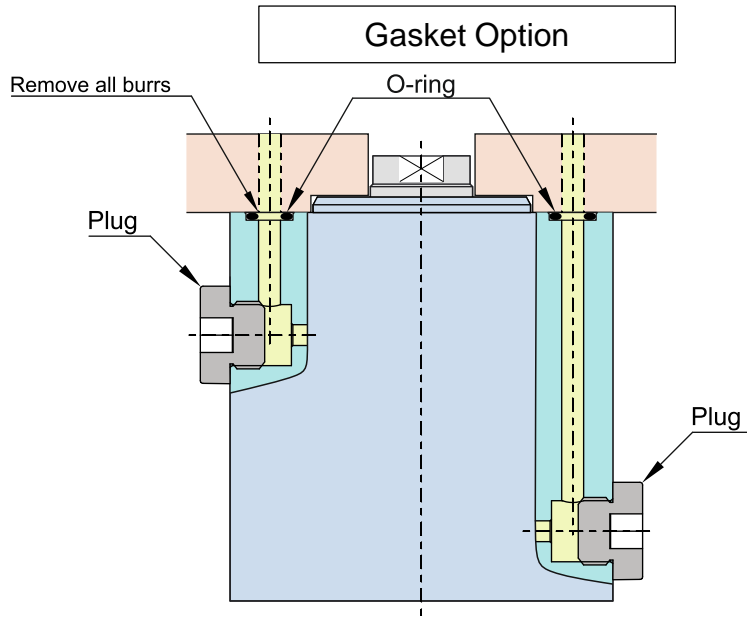

- In a gasket option, a flow control valve is mountable on G-ports of the cylinder.

Piping Option

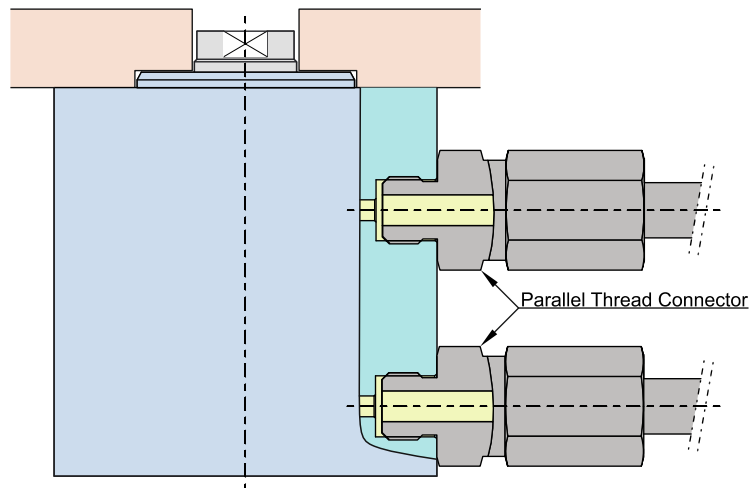

- Remove plugs for piping option. (For gasket option, to prefer piping installation for hydraulic fluid supply do not perform gasket hole in machining and close gasket line in cylinder with O-ring.)



Cautions

1. Check the usable fluid.
 - i.e. General Mineral Based Hydraulic Oil (ISO – VG32 Equivalent)
 - Make sure the hydraulic fluid not deteriorated.
2. Cylinder clamping method
 - Make sure no forces applied to the piston rod except from the axial direction. Otherwise it may cause a reduction in working life and leakages leading to the destruction of the cylinder.
3. Hydraulic supply
 - Never exceed the given pressure limit otherwise it will cause malfunction of the product.
 - If the flow rate is too high, excessive speed can be caused and lead to wear and damage to cylinder components.
 - The cylinder supply flow must be controlled, flow control valve must be installed.
 - The return flow from the cylinder must be free.
4. Procedure before piping
 - The pipeline, piping connector and fixture circuits should be cleaned by thoroughly flushing.
 - The dust and cutting chips in the circuit may lead to fluid leakage and malfunction.
 - There is no filter provided with product, which prevents foreign materials and contaminants from getting into the circuit.
 - While applying the sealing tape ensure that no pieces of sealing tape enters into the circuit, it can lead to oil leakage and malfunctions.
 - Please implement piping constructions in a clean environment to prevent anything getting into the product.
5. Do not touch cylinder while it is working, otherwise it may cause injury due to clinging.
6. Do not disassemble or modify the product.
 - If the product is modified, then malfunction occurs.
7. Please contact us for overhaul and repair.